



Poultry Automation and Incubation Control Devices

EPC-T10 (Poultry Automation Controller With HMI Touch Panel)

ESM-3721 (Single SET Digital Incubators Control)

ESM-3722 (Dual SET Digital Incubators Control)

EGG-HATCHER (Hatching Control Device)

Poultry Automation Control

Poultry Automation Controller
With HMI Touch Panel

EPC-T10



- ▶ 10.1" Wide Touch Screen TFT LCD
1024x600 resolution (16 million colors)
- ▶ 8 x RS-485 communication connection for Humidity + Temperature sensor

Specifications

HMI Touch Panel + I/O Module

- 19 Relay Outputs, 2 Analogue Outputs
- 8 Digital Inputs, 11 Analogue Inputs

Controls and Measurements

- Heating, Cooling, Ventilation, Humidity, Co2 and Ammonia measurements
- Feeding, Lighting, Weight Measurement, Consumption Calculation

Analogue Input Functions

- Poultry Internal Temperature Sensor, Static Pressure, Humidity, Co2, Nh3
- Shutter Feedback, Outside Temperature Sensor
- Feed Measurement Sensor

Digital Input Functions

- Energy Consumption, Electricity Consumption, Water Consumption
- Feed Consumption, Negative Pressure

Relay Functions

- Fan, Heater, Cooling, Shutter Opening-Closing,
- Lighting, Feeding, Alarm, Humidity
- Cooling Shutter On / Off

Analogue Outputs

- Lightings, Fans, Heaters

EPC-T10 Block Diagram

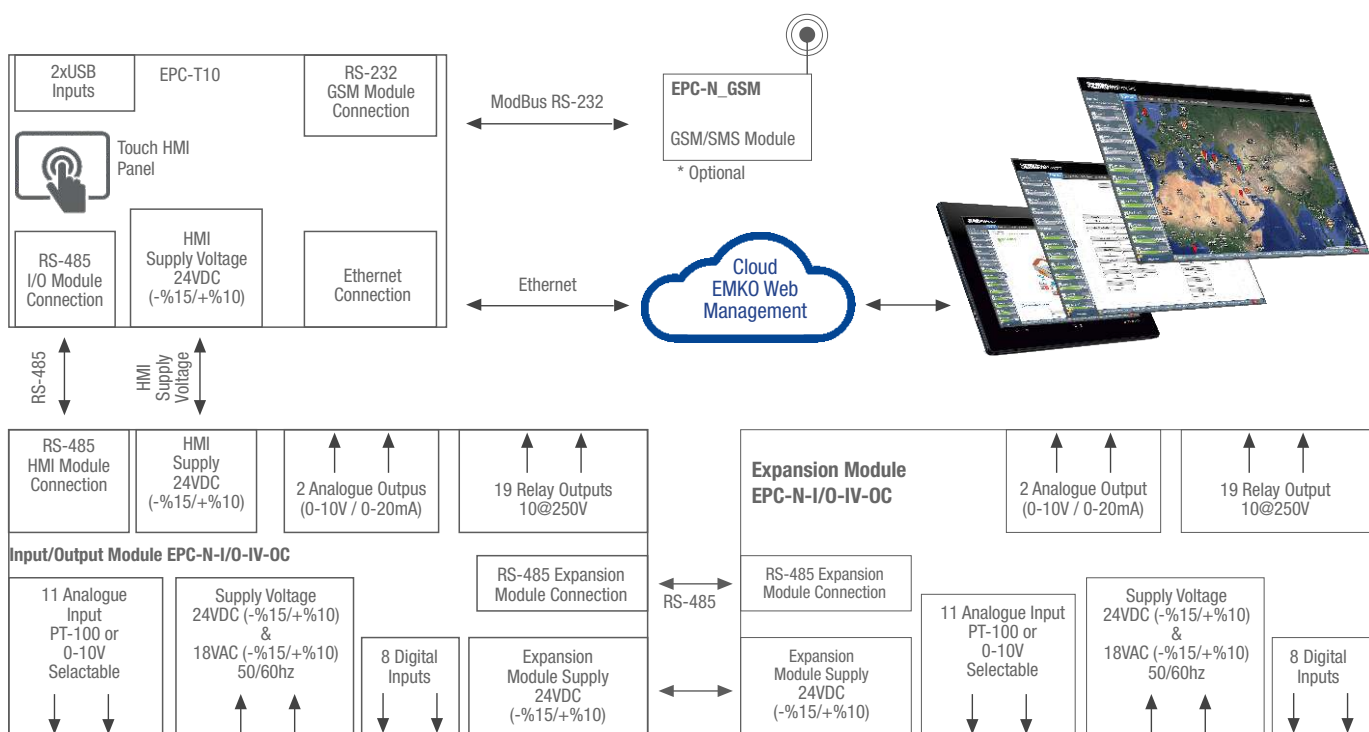

* Max. 2 Input/Output modules can be connected to EPC-T10 HMI panel

Poultry Control and Monitoring
 In your Computer,
 In your Tablet
 In your Mobil Phone
 With **EMKO Web Management**

Poultry Automation Control

EPC-T10



Remote Monitoring and Control
 Multiple Poultry Visualisation
 Measurement Values and Static Analysis

► EPC-T10 Poultry Control & Monitoring Data

- CONSUMPTION
- LIGHTING
- AGE CURVE
- ELECTRICITY
- WEIGHT
- WATER
- FEEDING

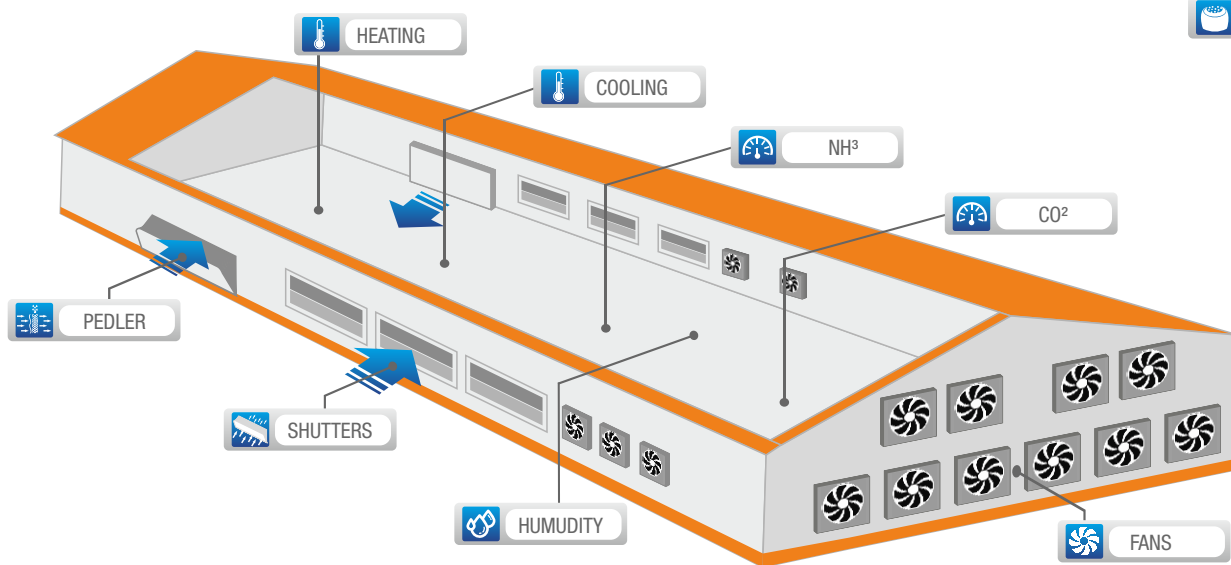

Product Order Code	Description
EPC-T10	<u>ECP-T10 (10.1" Touch HMI module)</u> 2xUSB, 1x Ethernet, 1xRS-232 (For GSM module) 1xRS-485 (I/O card) communication port
EPC-N-I/O-IV-OC	<u>EPC-N-I/O-IV-OC Input-Output and Expansion Module</u> 2xRS-485 communication port (For I/O module communication) , 8 Digital Inputs, 19 Relay Outputs (10@250V) 11 Analogue Inputs (PT-100 or 0-10V selectable), 2x Analogue Outputs (0-10V/0-20mA)
EPC-N_GSM	GSM SMS Module (Antenna + 3m Communication Cable)
PMD-W-0/0.1.1.0	RS-485 communication, wall type , Humidity+Temperature sensors

* Max. 2 Input/Output modules can be connected to EPC-T10 HMI panel

Poultry Automation Remote Visualisation

Poultry Automation
Remote Monitoring Application
For Android / IOS operating systems

EPC MOBILE



- ▶ Instant monitoring of real-time notifications from the user's phone
- ▶ In the event of a problem with the Internet sending alarm information via SMS
- ▶ Alarm notifications are sent to the user's phone when alarms occurred

Specifications

- Access to alarm logs
- Multiple poultry visualisation
- Monitoring measured values
- Monitoring of heater status
- Pad motor monitoring
- Fan motor monitoring
- Water, feed consumption monitoring
- Monitoring the number of poultry
- Monitoring of ventilation level
- Average temperature monitoring
- Easy remote monitoring all over the world

▶ EPC Mobile Monitoring Data

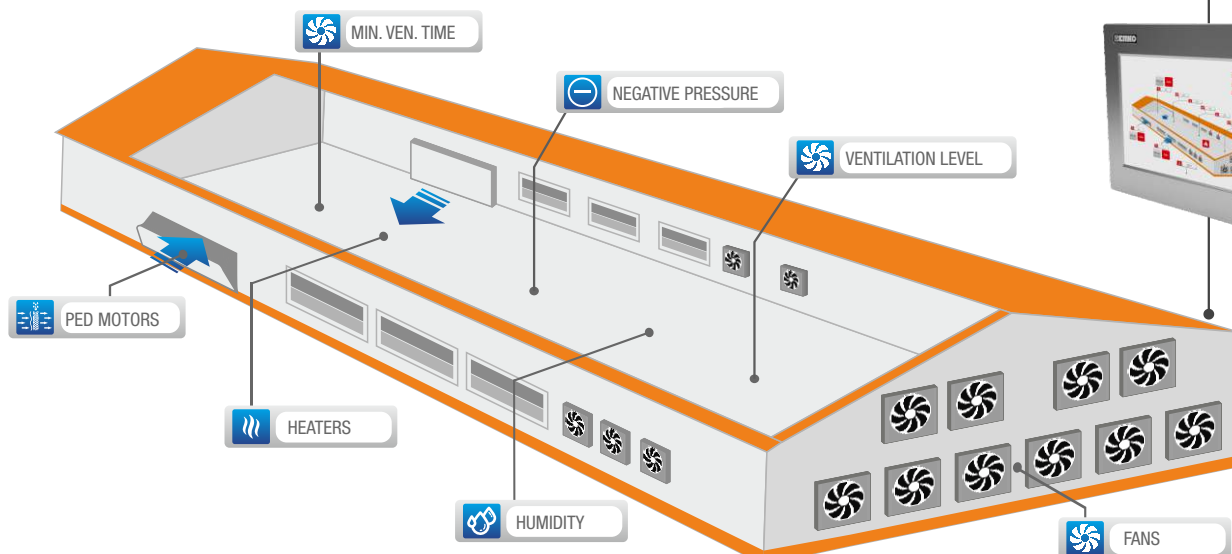



Hatching Control Device



Pronem-Mini

Incubation Control Instruments

EGG-HATCHER



- ▶ 320 x 240 Pixel TFT LCD
- ▶ (RTC) Real Time Time Operation

- ▶ Can Start the Incubation Period Minus Days
- ▶ On the Main Screen (Day, Hour, Minute) Display

Specifications

- Heating PID or ON/OFF
- Cooling ON / OFF Control
- Analogue input (mA, mV, V, PT-100, Pronem-Mini) (Must be determined in order)
- Humidity Control
- Shutter Control
- Tray Rotation Control
- Alarm Parameters
- Real Time Clock
- Event Logs

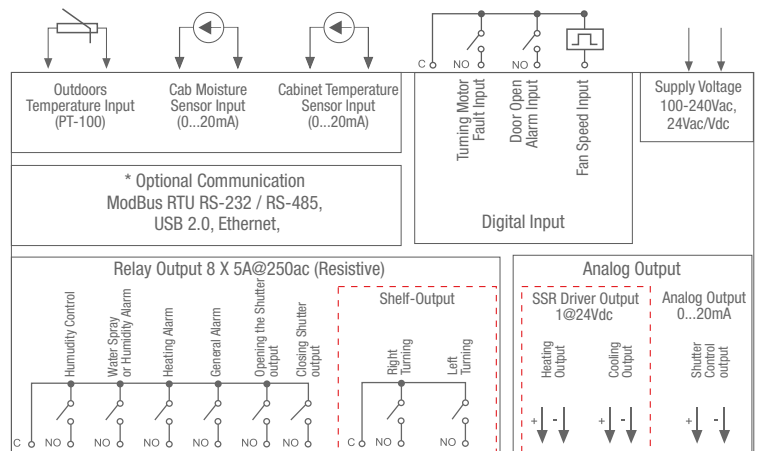

Technical Specification

- Temperature Sensor Input:** 0-20mA, PT-100 (IEC751)(ITS90),
- Temperature Sensor Input :** PRONEM MINI
- Measurement Range :** 0°C ... 100°C
- Accuracy:** ±0,25% of scale
- Sensor Break Protection:** Upscale
- Sampling Cycle:** 100ms

- Outputs :** Relay, SSR Driver, 0-20 mA or 0-10 V Analog Output
- Control Form :** ON/OFF, PID
- Storage / Operating Temperature :** -20°C to +70°C/ 0° to +50°C
- Pronem Mini Accuracy (RH) :** +/-2 %RH (Typ)@23°C
- Pronem Mini Accuracy (T) :** +/-0,3°C (Typ)@23°C
- Dimensions :** 96x96x96mm

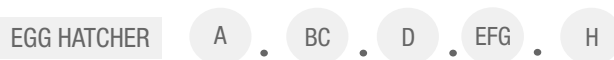

- A** Supply Voltage
- 1 100-240Vac 50/60 Hz (-%15; +%10)-6VA Universal
 - 2 24Vac 50/60 Hz (-%15; +%10) 24Vdc (-%15; +%10)

- B** Input Type
- 1 Configurable universal TC, RTD input
 - 2 Pronem-Mini PMI-P

- B** Output
- 1 8x Relay + 2x SSR + 1x Analog (0...20mA)

- H** Sensor Selection
- 0 There is no sensor in the device box
 - 6 PMI-P Pronem-Mini Digital Humidity Temperature Sensor (Max. 2,5mt cable)

- EFG** Communication
- 000 RS-232 ModBus RTU communication
 - 200 USB + RS-232 ModBus RTU communication
 - 20U RS-485 + RS-232 ModBus RTU communication
 - 240 Ethernet + RS-232 ModBus RTU communication
 - 2EU Ethernet + USB + RS-232 ModBus RTU communication
 - 24U USB + RS-485 + RS-232 ModBus RTU communication

Incubation Control Instruments

ESM-3722

Dual SET
Digital Incubators
Control



ProNem-Mini



▶ Temperature and Humidity
(NTC, PTC, PT-100 or ProNem Mini PMI-D)

▶ Auto-Tune PID

▶ Humidity Sensor Input
(0/2..10V, 0/4..20mA or ProNem Mini PMI-D)

▶ Egg Tray manual operation from front panel

Specifications

4 Digits Temperature and 4 Digits Humidity Display
Pronem PMI-P Temperature Sensor Input
Pronem Mini PMI-P Humidity Sensor Input
4 Output for
Temperature Control Output, Egg Tray Turning Output
Humidity Control Output, Alarm Control Output
PID or ON/OFF Selectable Temperature Control
Temperature and Humidity Set Value Boundaries
Alarm parameters and alarm status can be adjusted
according to the audible alert
(Internal buzzer functions for alarm conditions)
Password Protection for Programming Section

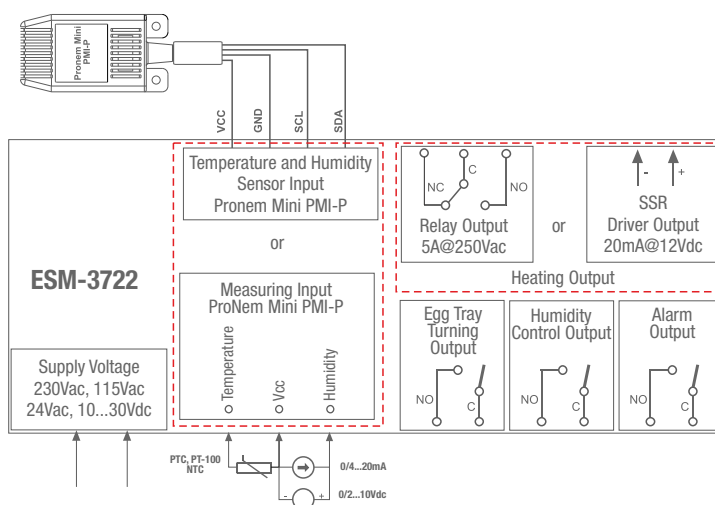

Technical Specification

ESM-3722 Measurement Range

PTC, NTC, PT-100, 0/2...10Vdc, 0/4...20mAdc, ProNem Mini PMI-P

Accuracy: ±1% of scale

Sensor Break Protection: Upscale

Sampling Cycle: 3 samples per second

Control Form: ON/OFF, PID

Storage / Operating Temperature : -40°C to +85°C/ 0° to +50°C

Pronem Mini Accuracy (RH): +/-2 %RH (Typ)@23°C

Pronem Mini Accuracy (T): +/-0,3°C (Typ)@23°C

Dimensions : 76x34,5x71mm

ESM-3722 A . B . C . D . E / 01 . HI / 1 . V . W . 0

- A** Supply Voltage
- 2 24Vac/dc 50/60 Hz (-%15; +%10)
 - 3 24Vac 50/60 Hz (-%15; +%10)
 - 4 115Vac 50/60 Hz (-%15; +%10)
 - 5 230Vac 50/60 Hz (-%15; +%10)
 - 8 10..30Vdc 1.5W

- B** Temperature Sensor Input
- 1 PT 100, IEC751(ITS90)
 - 2 PTC (Not-1)
 - 3 NTC (Not-1)
 - 4 0/2..10Vdc Voltage Input
 - 5 0/4..20mA Current Input
 - 66 * ProNem Mini PMI-P

- E** Heating Control Output
- 1 Heating Control: Relay (5A @ 250Vac)
 - 2 SSR Driver Output (Maximum 30mA @ 15Vdc)

- C** Humidity Sensor Input
- 4 0/2..10Vdc Voltage Input
 - 5 0/4..20mA Current Input

- V** **W**
- Sensor None 0 0
*PMI-P 6 6
- Alarm Output **U**
Relay (3A@250Vac) 1
- Egg Tray Turning Control Output **HI**
Relay (3A@250Vac) 01
- Humidity Control Output **FG**
(3A@250Vac) 01

* When ProNem is selected, BC code is written as 66

* PMI-P (Pronem-mini digital Humidity and Temperature Sensor - Max.2,5mt cable)



Single SET
Digital Incubators
Control

Incubation Control Instruments

ESM-3721



- ▶ Temperature ON/OFF and PID Control Selectable
- ▶ Heating Control Output, Egg Tray Turning Output, Alarm Control Output
- ▶ Egg Tray manual operation from front panel
- ▶ Auto-Tune PID

Specifications

4 Digits Display
PTC input
Set Value Boundaries
Alarm parameters and alarm status can be adjusted according to the audible alert (internal buzzer functions for alarm conditions)
Password Protection for Programming Section

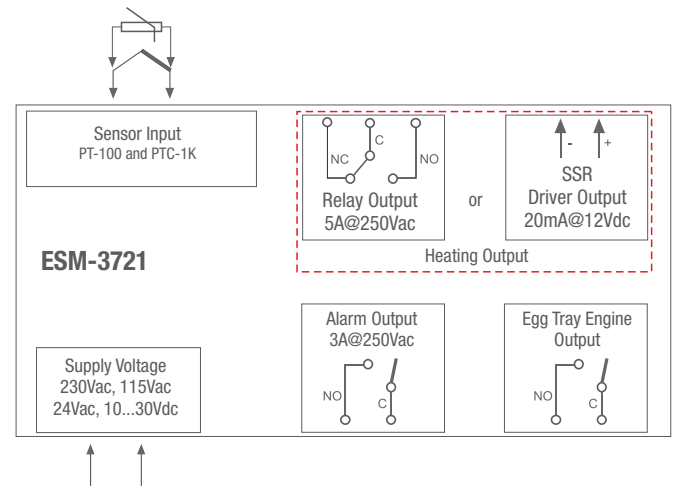

Technical Specification

Temperature Sensor Inputs : PT-100 (IEC751)(ITS90), PTC-1K
Measurement Range : 0°C ... 100°C
Accuracy: ±1% of scale
Sensor Break Protection : Upscale
Sampling Cycle : 3 samples per second
Outputs : Relay, SSR Driver Output

Relay Output : 5A@250Vac “at resistive Load” (Heating Output)
3A@250Vac “at resistive Load”(Egg Tray Engine and Alarm Output)
(Electrical Life: 100,000 Switching at Full Load)
Protection Clas : NEMA 4X (IP65 at front Ip20 at read)
Storage / Operating Temperature : -40°C to +85°C/ 0° to +50°C
Dimension : 76x34,5x71mm

ESM-3721 A . BC . 0 . E / 01 . 01 / 1 . V . 0 . 0

<p>A Supply Voltage</p> <p>2 24Vac/dc (±%15) 50/60Hz - 1.5VA</p> <p>3 24Vac (±%15) 50/60Hz - 1.5VA</p> <p>4 115Vac (±%15) 50/60Hz - 1.5VA</p> <p>5 230Vac (±%15) 50/60Hz - 1.5VA</p> <p>8 10...30 Vdc - 1.5W</p>	<p>BC Sensor Input</p> <p>09 PT 100</p> <p>12 PTC-1K</p>	<p>E Heating Control Output</p> <p>1 Relay Output (Max. 5A@250Vac)</p> <p>2 SSR Driver Output (Max. 20mA@12Vdc)</p>	<p>V Sensor Selection</p> <p>Sensor None 0</p> <p>*PTC-1K Sensor 1</p> <p>*RTS-3721 5</p> <p>H Egg Tray Engine Output</p> <p>Relay Output (Max. 3A@250Vac) 01</p> <p>FG Alarm Output</p> <p>Relay Output (Max. 3A@250Vac) 01</p>
---	---	--	---

* PTC-1K : PTC-M6L40.K1,5 (Supplied PTC-1K sensor)
* RTS-3721 : RT-M6L40.K1,5 (Supplied PT-100 sensor)

